



MARK ANDY



2200

MAXIMUM EFFICIENCY

INTEGRATED SERVO DESIGN

FILM CAPABLE



Upgraded by the customer Upgraded for the operator

MORE VERSATILITY ■ MORE DEPENDABILITY ■ MORE PROFITABILITY

Fully upgradable this press can grow and expand as business needs change and evolve.

Key Technologies on the 2200:

Advanced Web Tension Management

- > Vertical dancer inherently stable, providing linear unwind tension control
- > Splice platform integrated with new standard web guide
- > A/C motor controlled rewind with taper tension standard

Die Station Upgrades

- > Standard 2½" (63mm) slots
- > Larger anvil rolls – 10 TIMES more rigid!

Improved Drying & Curing

- > High efficiency dryer system
- > Automated ramping of heat with press speed
- > Combination UV/hot air drying with a single web path
- > Fully integrated UV systems by UVT

Exclusive Servo Design

- > Intuitive digital control
- > Fully automated registration control
- > Servo power at every component – infeed to rewind

Operator Master Control Panel

- > State-of-the-art touch screen design
- > Simple access and control of all press functions
- > Distributed controls for ease of operation and future expansion

Advanced Print Stations

- > Self-aligning cassettes – effortless removal and installation speeds up changeover time
- > Ultra-stable off-line design – designed to support many LEAN manufacturing programs
- > Robust print station – more rigid design reduces plateroll “gap” bounce

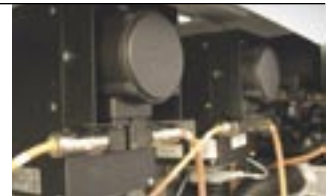

PERFORMANCE SERVO PACKAGE

- > Fully integrated – from infeed to rewind
- > Broad substrate range – 25 micron BOPP films to heavy tag stock
- > Intuitive servo functionality
- > Best in its class!



Ergonomic printing cassette, easily moved to 'self aligning' track
 > Allows for faster change-over, clean-up and set-up

Vertical dancer
 > Enhances substrate control

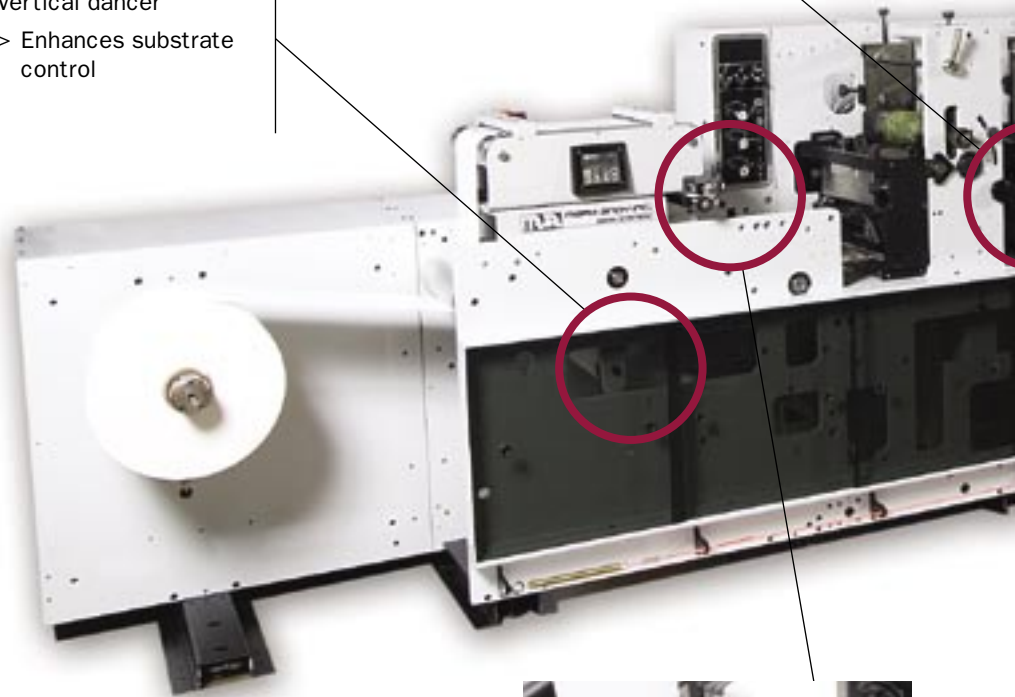

OPTIONAL PRINT SOLUTIONS

- > Film capable – 25 micron BOPP
- > Variable web paths
- > Web turn bar
- > Delam/relam
- > Corona treater
- > High velocity hot air drying
- > UV curing with single web path
- > Viewing and inspection systems
- > Web cleaner
- > Mechanical design



Infeed options:
 > Constant torque
 > Closed loop control
 > Servo controlled

OPTIONAL CONVERTING SOLUTIONS

- > Additional dual die modules
- > Underside die cutting
- > Additional waste wind-up
- > Additional rewind spindle
- > Fan folder and drive
- > Punch unit
- > RD Scorer
- > CK Slitter
- > Conveyor
- > Laminator

For custom designs, our Custom Design Team can develop a variety of printing and converting solutions to meet many specialized applications. Ask your representative about custom design solutions.

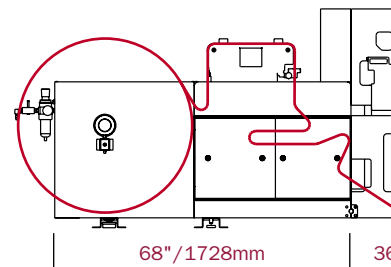

g
mounts
rack
r off-line
t-up

Heavy duty air clutch driven
waste wind up – 32" (813mm)
> Provides high torque
and cooler operation

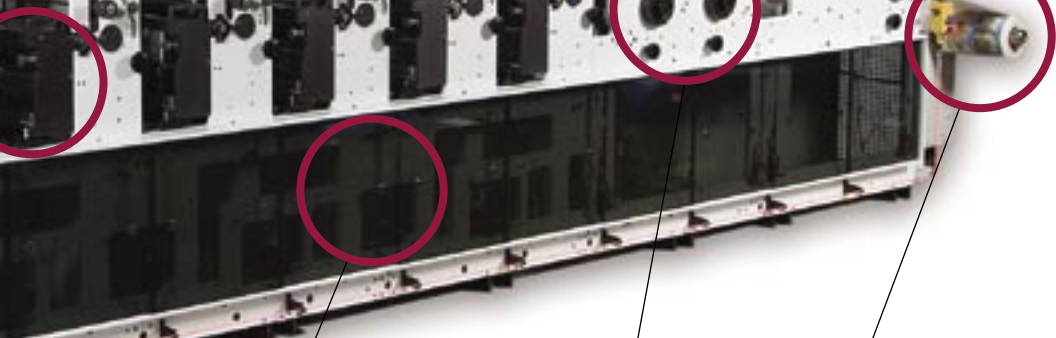

Giant 40" (1016mm)
rewind with taper
tension control
> Provides uniform
tension throughout
entire roll size

High efficiency curing
and drying designs
> Film capable – from 25 micron BOPP
> UV curing systems by UVT

Heavy duty die station –
10 times more rigid than
support role driven models
> Longer die life
> Better cut consistency
> Less friction & heat build-up

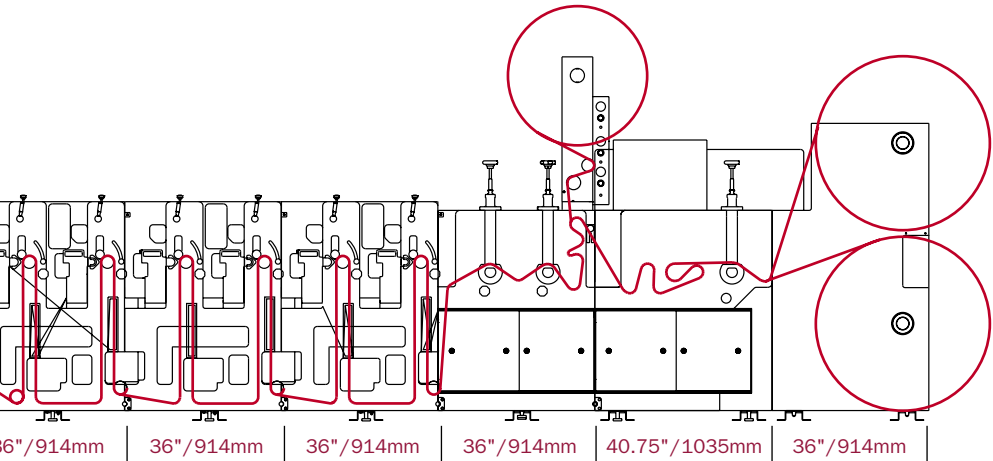

Length overall 6-color – 24'/7.33m



Mark Andy is the leading machine designer and manufacturer in the printing and converting industry, with more than 7000 installations world-wide. But our interest doesn't stop at the equipment – we form partnerships with our clients that empower them to increase productivity, efficiency, and ROI. Backed by decades of experience, Mark Andy supports you with full-house engineering, complete custom-design, print management and manufacturing, all from a single source.

Legendary performance optimized for today — Adaptable for the future

The 2200 is available in three option packages, all upgradable and flexible. Various levels of options provide maximum versatility and customization never before seen.

The 2200 has been completely re-engineered delivering versatility and flexibility to support any expanding business.

2200L	2200XL	2200SERVO
<p>Start-up</p> <p>Begin with a 2200L, the most economical solution, and deliver award winning labels at an entry-level price. It doesn't stop there. <i>The 2200L can be upgraded as your business grows and evolves.</i></p>	<p>Next Generation</p> <p>The fully capable 2200XL is the next generation. It is the right solution for established printing businesses with proven success. With additional upgrades to the L model, this premium print platform adds value with <i>higher run speeds and faster change-over times.</i></p>	<p>Superior Printing System</p> <p>The premium servo package comes with standard 750 fpm (230m/min) speed, fully automated registration and a variety of drying and curing options. <i>The ultimate value in delivering the fastest production speeds and control functionality. Make-ready entire print station during a run with the drawer out!</i></p>

Now you have all the options to expand your possibilities!

Feature	2200L	2200XL	2200SERVO
Print Width 10"/254mm	■	■	■
Print Width 13"/330mm	■	■	■
Print Width 17"/432mm		■	■
MIN Print Repeat (10")	5½"/140mm	5½"/140mm	5½"/140mm
MIN Print Repeat (13"/17")	7"/178mm	7"/178mm	7"/178mm
MAX Print Repeat	24"/610mm	24"/610mm	24"/610mm
MAX Die Repeat	24"/610mm	24"/610mm	24"/610mm
MAX Die Repeat – underside 3" (76mm) BR	22½"/572mm	22½"/572mm	22½"/572mm
MAX Die Repeat – underside 4" (102mm) BR	19¼"/489mm	19¼"/489mm	19¼"/489mm
MAX Print Stations	8	12	12
Unwind Capacity	40"/1016mm	40"/1016mm	40"/1016mm
Rewind Capacity	40"/1016mm	40"/1016mm	40"/1016mm
Speed 500 FPM (154m/min)	■	■	
Speed 750 FPM (230m/min)		optional	■
"QC" Quick Change Cassette*	■		
"QC" Quick Change Drawer		■	
"QC" Quick Change Drawer w/anilox motor			■
Open loop brake infeed pacing		■	■

*N/A on 17"

World Class Service

All Mark Andy equipment is backed 100% by MAX, the customer service and support arm of Mark Andy Inc. With the largest team of technicians and parts specialists in the narrow web industry, MAX is dedicated to enhancing the customer's productivity, improving print quality and guiding the customer in new applications.

Our certified technicians and specialists provide:

- > Installation
- > Training
- > Preventive Maintenance
- > Parts
- > Retrofits
- > Consumable Products

MAX supports customers with the knowledge and experience that only an OEM service team can provide. For additional information about MAX, including the products and services available, visit www.yourfriendinflexo.com.

MARKANDY

Mark Andy Inc.

Tel +1 636 532 4433
Fax +1 636 532 1510
18081 Chesterfield Airport Rd.
P.O. Box 1023
Chesterfield, MO USA
63006-1023

Mark Andy AG

European Headquarters

Tel +41 61 487 96 66
Fax +41 61 487 96 65

Mark Andy UK

Tel +44 1625 500964
Fax +44 1625 501334

Mark Andy France

Tel +33 1 64 60 39 90
Fax +33 1 64 60 39 98

www.markandy.com